

Product information presented here reflects conditions at time of publication. Consult factory regarding discrepancies or inconsistencies.

Patent No. 8,535,014  
 Automatic model only

## TECHNICAL DATA SHEET

EXPLOSION PROOF OR DUST-IGNITION PROOF RATED SERIES\*

Models X292, X293, X294, X295 Submersible Sewage Pumps for Hazardous Locations  
 Class I, Division 1, Groups C & D Rated and Class I, Zone 1, Groups IIA & IIB Gas Areas  
 or  
 Class II, Division 1, Groups E, F & G and Zone 20 Dust Areas

### PRODUCT SPECIFICATIONS

<b>MOTOR</b>	Horse Power	1/2 (X292), 1 (X293), 1-1/2 (X294), 2 (X295)
	Voltage	115 - 575
	Phase	1 or 3 Ph
	Hertz	60 Hz
	RPM	3450
	Type	Permanent split capacitor or 3 Ph
	Insulation	Class B:X292-X293, Class F:X294,X295
	Amps	2.4 - 20.5
	<b>PUMP</b>	Operation
Auto On/Off Points		19-1/2" (495 mm) / 10" (25.4 cm)
Discharge Size		2" or 3" NPT female, flanged vertical
Solids Handling		2" (50 mm) spherical solids
Cord Length		20' (6 m) standard
Cord Type		1 Ph-UL listed 5-wire neoprene cord 3 Ph-8 wire with no plug
Max. Head		75' (22.9 m)
Max. Flow Rate		214 GPM (810 LPM)
Max. Operating Temp.		104 °F (40 °C)
Cooling		Oil filled with finned housings
Motor Protection		Auto reset thermal overload (1 Ph) or thermal sensor (3 Ph)
<b>MATERIALS</b>	Upper Bearing	Ball bearing
	Lower Bearing	Ball bearing
	Mechanical Seals	Carbon and ceramic with stainless steel parts
	Impeller Type	Non-clogging vortex
	Impeller	Cast iron, optional bronze
	Hardware	Stainless steel
	Motor Shaft	416 stainless steel
	Gasket	Neoprene square ring

### AUTOMATIC

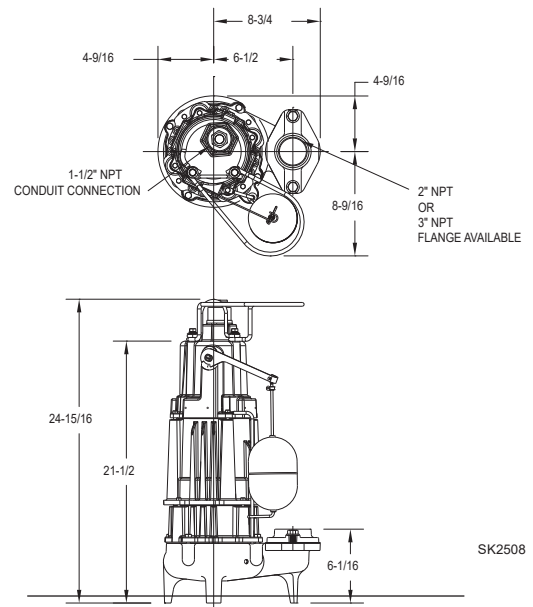

### NONAUTOMATIC

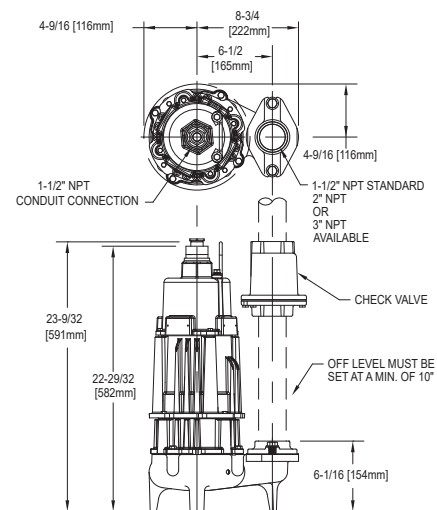

All Class 30 cast iron construction.

NOTE: The sizing of a pump system normally requires variable level float(s) controls and properly sized basins to achieve required pumping cycles or dosing timers with nonautomatic pumps.

NOTE: \*Pump tags will be specific to either gas or dust areas

**CAUTION** Model X293 should not be subjected to less than 15' (5 m) TDH.



# TOTAL DYNAMIC HEAD FLOW PER MINUTE

MODEL		X292		X293		X294		X295	
Feet	Meters	Gal.	Liters	Gal.	Liters	Gal.	Liters	Gal.	Liters
5	1.5	135	511	--	--	196	742	214	810
10	3.0	120	454	--	--	181	685	199	753
15	4.6	104	394	122	462	165	625	186	704
20	6.1	87	329	111	420	150	568	173	655
25	7.6	70	265	99	375	136	515	161	609
30	9.1	51	193	85	322	124	469	149	564
35	10.7	29	110	69	261	112	424	137	519
40	12.2	--	--	51	193	99	375	124	469
50	15.2	--	--	6	23	67	254	98	371
55	16.8	--	--	--	--	46	174	83	314
60	18.3	--	--	--	--	16	61	66	250
70	21.3	--	--	--	--	--	--	23	87
Shut-off Head:		40 ft.(12.2m)		51 ft.(15.5m)		62 ft.(18.9m)		75 ft.(22.9m)	

009919

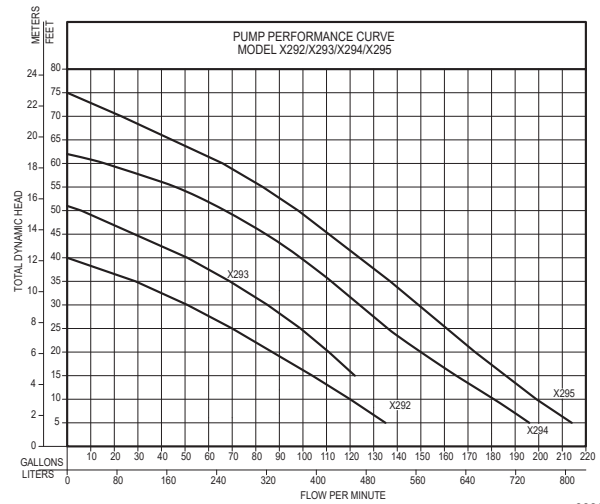

009919

**CAUTION** Model 293 should not be subjected to less than 15' (5 m) TDH.

Model	MODEL COMPARISON										
	Seal	*Mode	Volts	Ph	Amps	HP	Hz	Lbs	Kg	Simplex	Duplex
MX292	Single	Auto	115	1	15.0	1/2	60	123	56	2 & 3	---
NX292	Single	Non	115	1	15.0	1/2	60	118	54	1 & 2	1 & 2
DX292	Single	Auto	230	1	7.5	1/2	60	123	56	3 & 4	---
EX292	Single	Non	230	1	7.5	1/2	60	110	49	1 & 2	1 & 2
HX292	Single	Auto	200	1	8.8	1/2	60	123	56	3 & 4	---
IX292	Single	Non	200	1	8.8	1/2	60	110	49	1 & 2	1 & 2
FX292	Single	Non	230	3	5.2	1/2	60	121	55	1 & 2	1 & 2
JX292	Single	Non	200	3	6.4	1/2	60	121	55	1 & 2	1 & 2
GX292	Single	Non	460	3	2.9	1/2	60	121	55	1 & 2	1 & 2
BAX292	Single	Non	575	3	2.4	1/2	60	121	55	1 & 2	1 & 2
DX293	Single	Auto	230	1	10.2	1	60	123	56	2 & 3	---
EX293	Single	Non	230	1	10.2	1	60	118	54	1 & 2	1 & 2
HX293	Single	Auto	200	1	12.0	1	60	123	56	2 & 3	---
IX293	Single	Non	200	1	12.0	1	60	121	55	1 & 2	1 & 2
FX293	Single	Non	230	3	7.6	1	60	121	55	1 & 2	1 & 2
JX293	Single	Non	200	3	8.2	1	60	121	55	1 & 2	1 & 2
GX293	Single	Non	460	3	4.0	1	60	121	55	1 & 2	1 & 2
BAX293	Single	Non	575	3	3.3	1	60	121	55	1 & 2	1 & 2
DX294	Single	Auto	230	1	13.7	1-1/2	60	128	58	2 & 3	---
EX294	Single	Non	230	1	13.7	1-1/2	60	121	55	1 & 2	1 & 2
HX294	Single	Auto	200	1	17.8	1-1/2	60	128	58	2 & 3	---
IX294	Single	Non	200	1	17.8	1-1/2	60	121	55	1 & 2	1 & 2
FX294	Single	Non	230	3	9.5	1-1/2	60	121	55	1 & 2	1 & 2
JX294	Single	Non	200	3	10.8	1-1/2	60	121	55	1 & 2	1 & 2
GX294	Single	Non	460	3	4.8	1-1/2	60	121	55	1 & 2	1 & 2
BAX294	Single	Non	575	3	3.8	1-1/2	60	121	55	1 & 2	1 & 2
DX295	Single	Auto	230	1	17.1	2	60	128	58	2 & 3	---
EX295	Single	Non	230	1	17.1	2	60	121	55	1 & 2	1 & 2
HX295	Single	Auto	200	1	20.5	2	60	128	58	2 & 3	---
IX295	Single	Non	200	1	20.5	2	60	121	55	1 & 2	1 & 2
FX295	Single	Non	230	3	12.2	2	60	121	55	1 & 2	1 & 2
JX295	Single	Non	200	3	14.3	2	60	121	55	1 & 2	1 & 2
GX295	Single	Non	460	3	6.1	2	60	121	55	1 & 2	1 & 2
BAX295	Single	Non	575	3	4.9	2	60	121	55	1 & 2	1 & 2

\*For non-auto models, water level switch is required to be set at a minimal off point of 10 inches to meet dust-ignition proof certification requirements. Additional cord lengths are available in 25' (7.6 m), 35' (11 m) and 50' (15 m).

All Models are, cCSAus certified for hazardous gas or dust locations.

Tested to FM Standards 3600 & 3615 & 3616 by CSA

## SELECTION GUIDE

1. See FM1705 for correct intrinsically-safe simplex or duplex panel
2. See FM0526 for variable level control switches rated 30VDC are used as a control activator. Quantity required dependent upon panel selection.
3. Automatic pumps with integral float-operated mechanical switch; no external control required
4. Automatic pumps: use the optional seal-failure panel (10-1031) to activate the moisture sensor circuit, for pump protection and when required by local codes.

© Copyright 2021 Zoeller® Co. All rights reserved.

502-778-2731 | 800-928-7867 | 3649 Cane Run Road | Louisville, KY 40211-1961 | zoellerpumps.com