

PRODUCT SPECIFICATION DRAWING

HydroFlame Firestop Sleeves (8", 10" & 12" Pipe)

Part Numbers
HF-M8, HF-M10 & HF-M12
HF-P8, & HF-P10
HFEXT81 (8"), HFPEXT101 (10") & HFEXT121 (12")

Technical Data for HydroFlame Firestop Device	
Product Test Criteria	
UL Fire Tested & Listed to UL1479 (ASTM E814) & CAN/ULC S115	
UL Ratings (consult individual product specs & UL Systems):	
"L": Yes; "F": 3 Hrs. typical; "W": Yes (With sealant. See UL Systems)	
Intumescent Fire Wrap Physical Properties, Performance	
Contains no solvents or carcinogenic fillers	
Color:	Gray/Black
Material shelf/store life:	Indefinite
Heat Expansion begins:	≈ 375°F (191°C)
Greatest Expansion:	575°F-1100°F (302°C - 593°C)
Constrained Expansion:	≥ 18 times volume
Free Expansion:	≥ 37 times volume
Expansion after accelerated weathering (tested to UL 1479):	
Temperature aging:	Pass - 270 days @ 158°F (70°C)
High humidity aging:	Pass - 180 days @ 97-100% humidity, 95°F (35°C)
Application Temperature:	Minimum 15°F (-9°C) / maximum 130°F (54°C)
Temperature Resistance:	Maximum 212°F (100°C)
Surface Burning Indicates (Per ASTM E84/UL 723):	
Flame spread:	5
Smoke developed:	5

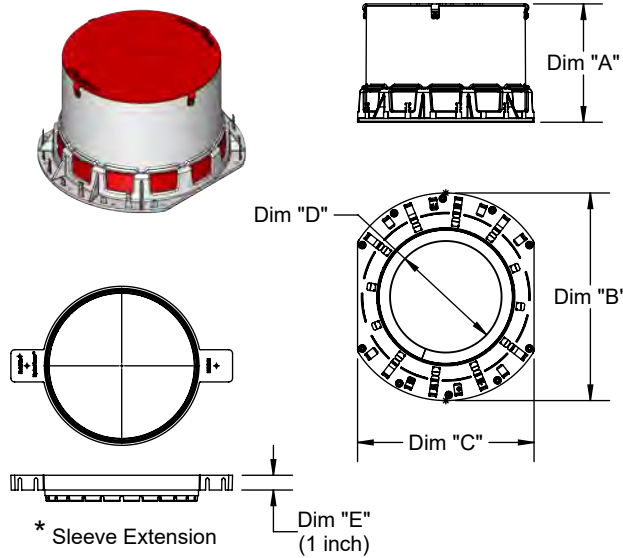

Size	Dim "A"	Dim "B"	Dim "C"	Dim "D"	Dim "A + E"
8"	8.0	14.1	12.0	Ø7.5	9.0
10"		16.3	14.1	Ø9.8	
12"		18.3	16.1	Ø11.8	

Note:

- Height range: For slabs 6" and above. Standard sleeve is 8" tall.
- * Sleeves can be extended by adding 1" sleeve extensions.

The **HOLDRITE® HydroFlame Firestop Sleeve Series** consists of assemblies that provide sleeving & firestop solutions for cast-in-place concrete floors. These sleeve products provide solutions for both metallic & non-metallic pipes, both insulated and non-insulated piping. For slabs 6" and thicker; 2 & 3 hour Fire Ratings. Sleeves are for use on flat form decks. 1" tall extensions are available. Each sleeve includes an OSHA-compliant hole cover plate / safety cap.

Product Information:

- Material:
 - Main Sleeve Body: PVC
 - Safety Cap: 11GA Steel
 - Smoke Seal: Intumescent Foam
 - Fire Ring: 18GA Steel
 - Firestop Material: UL Listed Intumescent Composite
- Patented & Patents Pending
- See Hydroflame Sleeve Installation Instructions & Best Practices documents and UL System documents

Product Submittal	
Job Name:	
Date:	
Part Number:	Qty:
Architect / Owner:	
Contractor:	
Notes:	



THIS INFORMATION IS PROPRIETARY TO HOLDRITE AND IS SUBJECT TO CHANGE WITHOUT NOTICE. IT MAY NOT BE REPRODUCED IN PART OR WHOLE WITHOUT WRITTEN AUTHORIZATION.

