

PRODUCT SPECIFICATION DRAWING

HOLDRITE® #270 Acoustical Isolation Liner

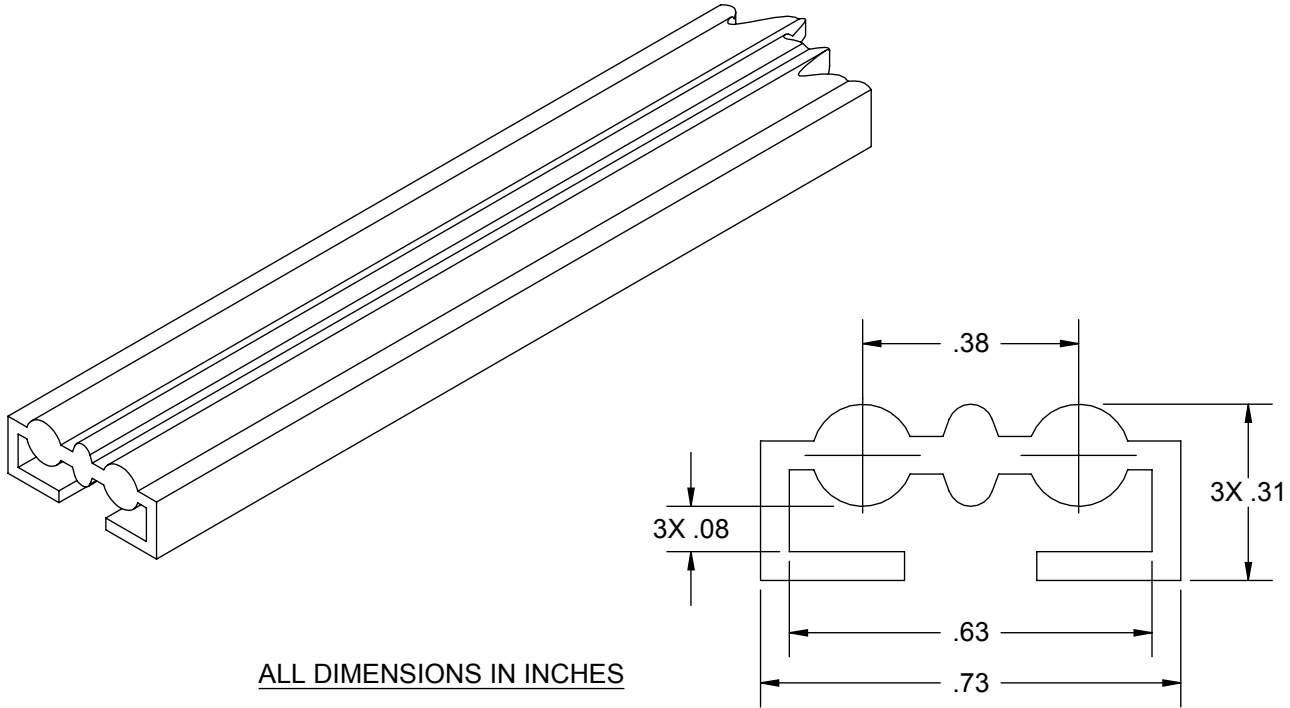

Engineered sound insulation lining, minimizes the occurrence of frictional noises caused by thermal expansion of the pipes and protects against contact between dissimilar materials. Attaches to ends of HOLDRITE Stout Brackets™ or around pipes to provide isolation from structure. Also provide sound isolation between metal loop hangers and piping. Available in 50' rolls.

Product Information:

- Material: TPE, 45 shore A, color white
- Temperature range: -30°F to 180°F



THIS INFORMATION IS PROPRIETARY TO HOLDRITE AND IS SUBJECT TO CHANGE WITHOUT NOTICE. IT MAY NOT BE REPRODUCED IN PART OR WHOLE WITHOUT WRITTEN AUTHORIZATION.



CONVERTING MAKESHIFT METHODS INTO ENGINEERED SOLUTIONSSM
 800-321-0316 OR 760-744-6944 / FAX: 760-744-0507 / WWW.HOLDRITE.COM
 spec_270A_RevE

Product Submittal	
Job Name:	
Date:	
Part Number:	Qty:
Architect / Owner:	
Contractor:	
Notes:	